



B I R K D A L E B U L L E T I N

APRIL 2009

MESSAGE FROM THE PRESIDENT'S DESK...

Hello everyone and Happy Spring! We have a few things going on in Birkdale that I would like to bring to your attention.

Many of you have asked for the board to look into the intersection of Royal Birkdale Blvd. and Royal Birkdale Drive, the entrance from Spring Run. We have spoken with the Chesterfield County Residency division of VDOT and have been instructed that we can add a stop sign to the center island as you approach Royal Birkdale Drive. They will not allow any other modifications to this intersection. Shortly, you will see another stop sign placed at that intersection.

Along the lines of traffic control, comes the issue of speeding. Thank you to all who have filed written and verbal complaints to the traffic division of Chesterfield County Police. We have been instructed that they will increase patrols in our neighborhood. Again, if you witness speeding and do not think it is being enforced to your satisfaction, voice your opinion to the traffic division of Chesterfield County at 318-8084 or by email: speeding@chesterfield.gov.

In the next few weeks you will all receive a letter from our managing agency that contains two major changes for our community. The first is a copy of the new Birkdale Complaints and Due Process Procedure. Under advisement from our association lawyers we strengthened our documents and procedures as to how to handle violations and violation reporting of our standards and guidelines. Please remember it is up to each of us to live by the guidelines of our association and encourage others to do the same. That is what helps to make Birkdale a "Great Place to Live". Also, in this letter, will be a formal change to section 6.22 of our standards and guidelines. This is the section on mailboxes. This has increasingly become the biggest areas of complaint by residents in our community. We have laid out in specific detail the look, height, width, colors of the Birkdale Mailboxes. Now, if your mailbox is in good condition, we are not saying that you need to rip out your mailbox and rebuild it. However, if your colors are not correct or your mailbox, post, or newspaper section has deteriorated you will be asked to conform to these newer standards. If you have the work done to repair your mailbox make sure your contractor conforms to these new standards as well. The ARC will be conducting a full inspection of our neighborhood on Saturday, April 18th; mailboxes along with everything else will be scrutinized.

Finally, our website, www.birkdaleonline.com, we are continuing to work on it and make it better with more content for residents and potential residents. We see this as a large project that is also an excellent marketing tool for us as a community. Over the next month we will be developing a sign up page for all members. We will be asking for your email address, we will not send it on to anyone, however, by December 2009, the Birkdale Bulletin will become paper less, and you will be able to read this online as a PDF file or we will email it to you. Look for that sign up section to be developed by late April.

As always if you have any questions, please feel free to contact me either by phone at 739-3162, or by email at president@birkdaleonline.com

Enjoy the Weather~

Matt DiNardo

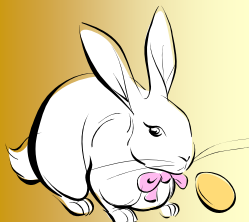



Birkdale Community Association Treasurer's Report

Through 3/24/09

As of March 24, 2009, the Association held the following investments:

Cash-First Association Bank DDA	\$ 54,651.46
MMA Capital One	\$ 2,622.12
CD Capital One 1/12 5.48%	\$ 23,485.26*
CD Provident 3/12 5.25%	\$ 43,200.41*
CD-First Capital Bank 8/12 4.78%	\$ 23,373.59*
 Total Cash	 \$147,332.84

The Birkdale Board Members

Matt DiNardo, President	739-3162	president@birkdaleonline.com
Barbara Dove, Vice President	608-8674	rdove34@verizon.net
Dani Fink, Secretary	639-1323	danifink1@comcast.net
Dan Lynch, Treasurer	739-3456	danlynch36@verizon.net
James Adams, Member at large	739-6743	jadams003@msn.com
David Trammell, Community Group	270-1800	dtrammell@communitygroup.com

Association Contact Names and Numbers

ARC—Don King	739-4582	
Project Care	—————	birkdale.project.care@verizon.net
Neighborhood Watch—Ted Lempke	399-2411	BirkdaleNW@verizon.net
Maintenance/Grounds—Joe Vanarsdall	739-2706	
Newsletter—Chelsey Kidd	639-4886	newsletter@birkdaleonline.com
Social Committee—Alisha Brady	744-6746	Birkdale_events@yahoo.com
Covenants Committee, Frank DiFazio	639-4574	fdifazio@verizon.net

Community Contact Names and Numbers

Women's Club—Maxine King	739-4582	
Swim Team—Tad Deriso	595-1270	Tad@mbc-va.com
Investment Club—Dottie Parker	639-1986	
Birkdale Clubhouse	739-8800	

NEWS FROM THE ARCHITECTURAL REVIEW COMMITTEE

As a reminder, on **Saturday, April 18th** (rain date May 9th) from noon to approximately 4:00 p.m., ARC will be conducting a residential property inspection for the purpose of determining if there are any violations to the current Birkdale covenants. Included in the inspections will be looking at the condition of mailboxes, appropriate service yards for trash receptacles and AC units, recreational equipment, yard maintenance, landscaping, fences, etc. If you do not have a copy of the ARC Guidelines and Standards document, please contact a member of ARC.

If you are planning on making a change to your property, please be sure to complete an application and submit it to the Birkdale Community Group Association.

ARC also wants to remind homeowners who have pets that they have the responsibility to not use common areas or other private property as their personal pet waste stations. The Birkdale community continues to experience residents not cleaning up after their pets. This is a health concern and in violation of the Birkdale Community Association Property Maintenance guidelines. The guidelines state: **“Residents are advised that they are subject to Chesterfield County ordinances regarding among other things licensing, leash laws and clean-up of animal waste material.”** We ask all Birkdale homeowners to be respectful of community property and abide by these guidelines. Thanks for your cooperation and assistance.

Upcoming ARC Meetings:

April 8th and 22nd

Applications recently approved by ARC:

8815 Thornton Heath Dr. – installing block wall system and timber to front yard landscape for purposes of correcting drainage issues.

9119 Spyglass Hill Terrace – Plantings in backyard for aesthetic and privacy.

8849 Pebble Beach Court – paint railings on both levels of deck to match trim on house.

8560 Sunningdale Terrace – install storm door to front of house.

8906 Spyglass Hill Court – Paint shutters and outside door.

14509 Leamington Dr. – install playground –swing set in backyard.

9136 Stonecreek Club Place – place decorator stone as a border for raised flower bed in back yard

ARC Members

Don King	739-4582
Larry Beuglass	639-4721
John Ratcliff	639-0820
George Sproveri	639-4550
Mary Wright	818-3159

Community Yard Sale
 Saturday, May 2, 2009 (Rain date May 9th)
 7:00 -12:00PM



The Goodwill truck will be on the left side of the club parking lot from 11-2:00 to collect your unsold items. Please do not leave them in the parking lot before the truck arrives.

April 2009

Sun Mon Tue Wed Thu Fri Sat

			1	2	3	4
5	6	7	8 ARC meeting	9	10	11
12	13	14 BWC meet- ing 7PM, club	15	16	17	18 ARC Inspec- tion
19	20	21 BWC Garden Tour	22 ARC Meeting	23	24	25
26 Swim Team Q&A	27	28 BWC Free Golf Lesson	29	30		

www.BirkdaleOnline.com



Current Features:

- Community News
- ARC Application and Instructions
- Contact Information
- Upcoming Events
- Classifieds
- Neighbor Connection
- Newsletter Archive

Still to Come...

- Governing Documents
- Meeting Minutes
- Photo Albums
- Area News
- Current Inventory
- Neighbor Log-in for electronic communication

Is there something you would like to see on our site? Let us know by contacting webmaster@birkdaleonline.com

4.14 COVENANTS COMMITTEE

When violations of these standards are discovered, homeowners are notified by mail of the violation and requested to correct the violation. When the homeowner does not correct the violation within the notified time-frame, the homeowner may be required to appear before the Covenants Committee. The Covenants Committee is comprised of Association homeowners and established to review noncompliant Architectural Standards violations and to provide a hearing forum so homeowners may state or defend their position. The Covenants Committee will rule either in favor of the homeowner, or negotiate a resolution, or rule against the homeowner. *If the Covenants Committee rules against the homeowner and determines that a violation exists, then the Covenants Committee or the Board will take formal action against the homeowner, including but not limited to, levying violation charges and possibly taking legal action. (Revised 3/2009)*

6.22. MAILBOXES

All mailboxes must be of the design and type approved by the ARC. *(See Flags 6.12.1.A)*

Mail boxes and all posts must be maintained in good condition in accordance with diagram 6.22.1 for design and specifications and the below standards. (Revised 3/2009) The only approved color combinations for mailboxes and posts are the following:

A *For all wood sections, including but not limited to the post and newspaper section:*

1. *Quart Size, Base color N103-1B comprised of pigment mixtures YW 0x 1.7500, OY 0x 1.7500, and GY 0x 2.2500; or*
2. *Gallon Size, Base color N103-1B comprised of pigment mixtures YW 0x 7.000, OY 0x 7.000, and GY 0x 9.000.*

B *For the mailbox only:*

1. *Quart Size, Base Color 110-4B comprised of pigment mixtures RX 0x 22.0000, BK 0x 9.5000, and MA 1x 6.000; or*
2. *Gallon Size, Base Color 110-4B comprised of pigment mixtures RX 2x 24.0000, BK 1x 6.0000, and MA 4x 24.000.*

These are Birkdale official pigment statements for the approved colors and can be purchased from Virginia Paint with the named colors of Vanilla Cookie for the wood sections, and Cottage Red for the Mailbox. (Revised 3/2009)

C *The only approved Birkdale Logos and street numbers are available from Acorn Sign and Graphics. These logos and numbers are placed flush against the wooden section of the newspaper section as shown in 6.22.1. Raised numbers are not acceptable nor allowed. Contact information: Acorn Sign and Graphics, 4109 West Clay Street, Richmond VA 23230, Telephone (804) 726-6999, and Facsimile (804) 726-6998. (Revised 3/2009)*

D *No other decorations, coverings, or alterations to mailboxes are allowed on or to the mailbox and post. (Revised 3/2009)*

Post: 6" x 6" x 8' Pressure Treated Wood

Paper Box: (2) 1" x 6" x 23"
(2) 1" x 8" x 23"

Base Moulding: (2) 1" x 6" x 12"
(2) 1" x 8" x 12"

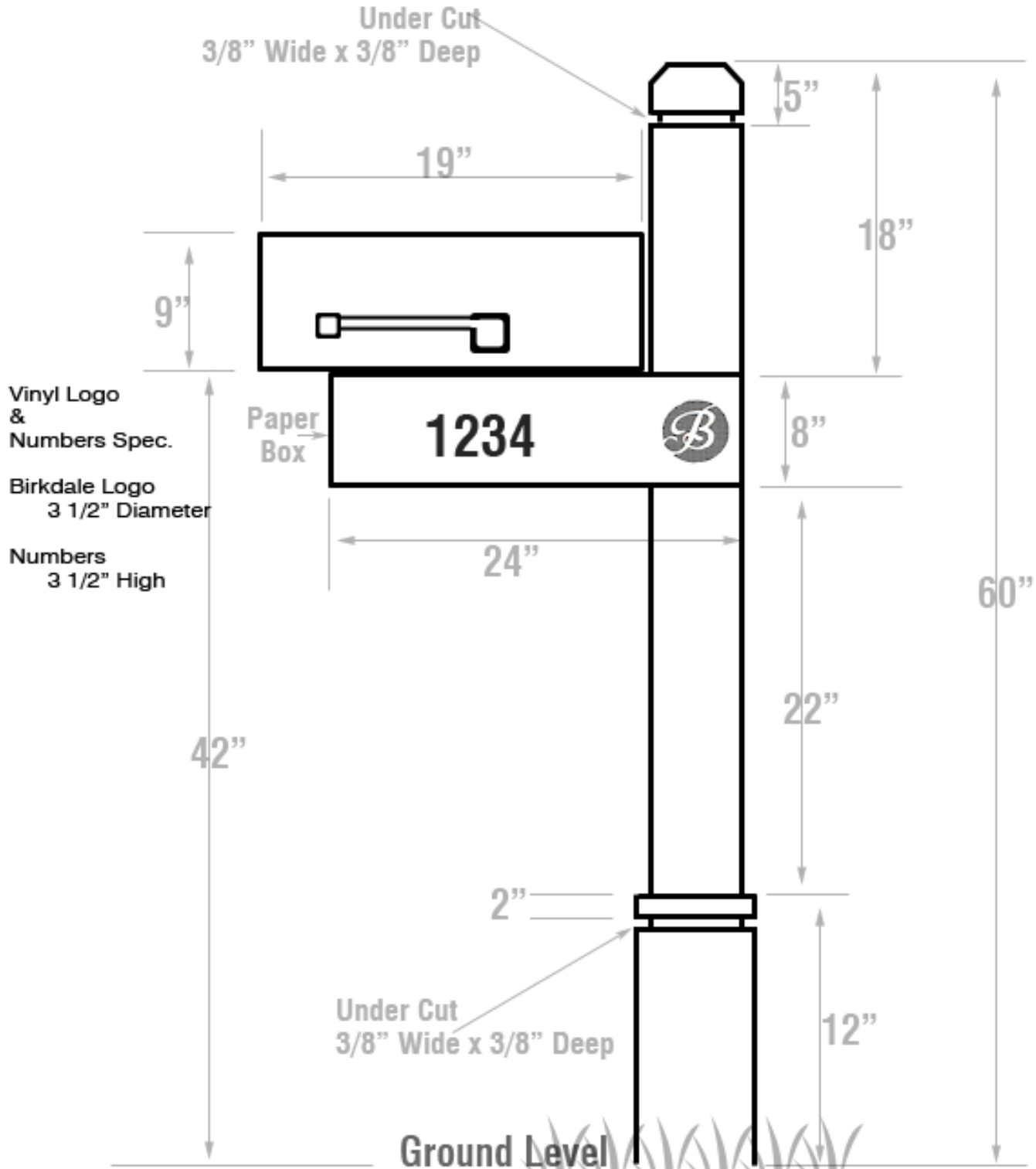

Birkdale Mailbox Diagram 6.22.1

Deadline for submission for May is April 23, 2009. Contact Chelsey Kidd at newsletter@birkdaleonline.com or 639-4886.

CHESTERFIELD COUNTY NEIGHBORHOOD WATCH



I think we all make the assumption that everyone knows how to call the police because we all know 911. Did you know that there are several other ways to call the Police?

When there is an emergency you should dial 911. However, there is also a non-emergency number 804-748-1251. This is the number that the police encourage you to call for suspicious activities, disturbances or crimes that are not actively in progress.

In addition, the Chesterfield County Police Dept. has a Traffic Complaint Hotline 804-318-8084 for speeding or traffic related complaints. This hotline was created for speeding or traffic complaints that do not need an immediate police response. We also encourage you to call Crime Solvers 804-748-0660. Crime Solvers is a way to report criminal activity anonymously and potentially earn a cash reward. Remember that there is a \$200 additional fine for speeding in Birkdale. Spring is here and your neighbors will be out and about. Please be cognizant of your speed to ensure the safety of everyone.

For our Neighborhood Watch to be a successful one, all of our watch members need to recognize and report any and all suspicious activity to the Police immediately.

Many people think that the police do not want to be bothered with so called petty situations but sometimes the reporting of those "petty situations" can help them solve big cases. For example, the occupants of a speeding car that just left the area may also have just vandalized several mailboxes, or the occupants may have broken into a house in the area. Whatever the situation, immediately calling the police better enables responding officers to be effective in dealing with the situation. When calling, if you wish, you may request to not be seen by responding officers.

National Night Out

This year National Night Out will be held on Tuesday August 4th. It is not too early to start planning your street's event. If your street did not have an event to celebrate National Night Out last year, you should consider doing so this year. This is the perfect opportunity to get to know your neighbors better. If you did have an event last year, then you should continue the tradition this year. Remember, knowing and communicating often with your neighbors plays a big part in having a successful and lasting Neighborhood Watch program.

Crime Report for February 2009

Date	Location	Type	Disposition 1	Disposition 2
02/01/09	08800 Thornton Heath Dr	MVA-NO INJ	Motor Vehicle Accident	Accident Report
02/12/09	08800 Spyglass Hill	Police Alarm Activated	Alarm Malfunction	No Report
02/13/09	08800 Thornton Heath Dr	Alarm – Hold Up	Accidental Alarm	No Report
02/20/09	14500 Leamington Dr	Drug Offense	Information	Drug Offense

Specific calls excluded from public viewing: mental subject, overdose, rape, search warrant, sex offense, suicide, terrorist incident, vehicle repossession.

NEWS FROM THE WOMEN'S CLUB

SPRING INTO APRIL WITH THE BWC SPECIAL EVENTS

The BWC is excited about the month of April. We will be hosting several events to spice up your spring. On April 14th at 7 pm at the clubhouse, we will have a speaker from Hudgins Nursery to describe the proper way to set up those beautiful container planters for your home. The speaker will include various types of plants and planters that will work well in different settings around your home.



Our annual Historic Garden Week Tour in Richmond will be held on April 21st. We will tour the West Hampton/Three Chopt Road area and then enjoy a luncheon at the Mosaic Restaurant. Everyone enjoys this outing year after year. Please plan to join us on this special trip. For more information call Linda at 739-2663.

On April 28th we will be offering our Free Golf Lesson presented by the Birkdale Golf Club between 5:30 – 7:00 pm. Then on May 12th between 6:30 – 8:00 pm at the Birkdale Tennis Courts, the club will offer a Free Tennis Lesson to BWC members. To participate, you must sign-up in advance and be a member of BWC.

BWC would like to thank everyone who came out in support of our first Charity Bingo Night. A special thanks to all of our volunteers and to Joe Vanarsdall our Bingo caller and Pete Bramble our checker. We had a wonderful evening and raised \$200 for the Central Virginia Food Bank. Our sponsors for the evening included: Rico's Mexican Restaurant, Jade Nails, Zhen Garden Restaurant, Vinny's Pizzeria, Sergio's Restaurant, Brick House Diner, His & Hers Salon, Curves, Avon and Tastefully Simple. Please visit these local establishments as a way of thanking them for supporting this event.



Join the Birkdale Fights Back! team to participate in the 2009 Race for the Cure on Saturday, May 9th. Go to the Race for the Cure website www.KomenRichmond.org, then choose Join an Existing Team from the right-hand side tabs. Type in Birkdale Fights Back! and follow the registration instructions.

Can't join the team, but would like to support the cause? Go to the Donation Page and sponsor either a participant or the team as a whole.

Thank you for helping in the fight against breast cancer!

UPCOMING EVENTS OF THE BWC

April 14th - Home container planting with speaker from Hudgins Nursery

April 21st - Historic Garden Week in Richmond Tour

April 28th - Free Golf Lesson - BWC members only

SOCIAL COMMITTEE NEWS



Birkdale Derby & Wine Festival

May 30, 2009

Post Time 6:00, Last Call 11:00

Dust off those derbies and bring your finest wine pallet. The Birkdale Social Committee along with Birkdale Golf Club invites you to an evening of entertainment. May 30 join us starting at 6pm for a host of wonderful wines to taste from all over the US and around the world. Be sure to bring your good luck charm for the excitement of Mock Horse racing, door prizes and music for everyone to enjoy. \$12.50 per person includes wine tasting, light appetizers and the horse racing festivities. For more information please contact Alisha Brady at 804-744-6746 or Birkdale_events@yahoo.com. RSVP's & payment must be received by May 17.



This is an ADULTS ONLY event!

I'm feeling lucky!

*Derby and Wine Festival *May 30* 6-11PM*

Name _____ *Number Attending* _____

Street Address _____

Email Address _____ *Amount Enclosed (\$12.50pp)* _____

Please make **checks out to Alisha Brady** and drop or mail them to 8549 Sunningdale Terrace, Chesterfield, VA 23832. Tickets will be emailed to you or dropped off if you don't have email access.

Birkdale Barracudas

Grab that bathing suit, put on those goggles, and get ready to “eat my bubbles”! It is that time of year again when the Birkdale Barracudas get ready to hit the pool. The Barracudas are the swim team of the Birkdale community. If you have never swum on a team and can make it across the pool unassisted, then the swim team is for you! We take all swimmers from Kindergarten up to Seniors. It is a great opportunity to meet new friends, cheer on your team, have some fun, and get great exercise.

Our coach will again be Birkdale’s own, Liz Shoulders, who is returning with more excitement and ideas to build this team. Practices will begin on June 2nd and the season ends with Championships on July 26th. There are 6 meets with 3 of them being at our own pool. **We will be having a Q&A session on Sunday, April 26th from 2-3 at the clubhouse.** All of the board members and the coaches will be there to answer any questions, so if you’re considering joining the swim team, this is the time to find out what we’re all about. If you have any questions, please contact our team president, Tad Deriso, 595-1269 or Tad@mbc-va.com. Hope to see you all there!

Swim team registration will be May 3rd from 2-4PM at the clubhouse

Birkdale

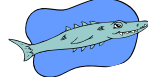

Barracudas SWIM TEAM



Hot, fresh Krispy Kreme doughnuts delivered to your house on

Yard Sale Day Saturday, May 2nd,

between 7:00-8:00 AM.

Please make check payable to Chelsey Kidd (Swim Team Fundraising Coordinator) and deliver it to 8805 Thornton Heath Drive by Saturday, April 25, 2009.

Name: _____

Number of boxes (\$5 each): _____

Address: _____

Phone: _____

Email: _____

Deadline for submission for May is April 23, 2009. Contact Chelsey Kidd at newsletter@birkdaleonline.com or 639-4886.